

Dialog 3213

System Telephone for MD110 Communication System

User Guide

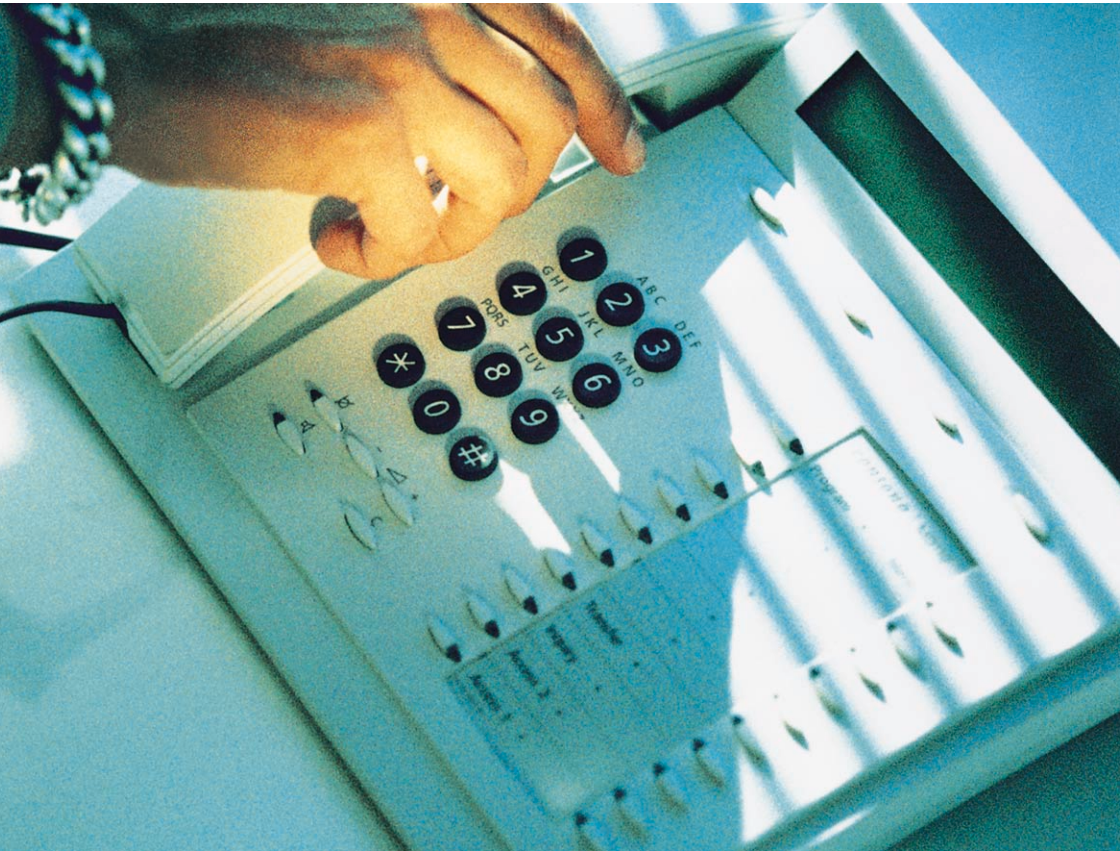

Welcome to the User Guide for the Dialog 3213 system telephone in the Ericsson MD110 communication system, release BC11. It is a state-of-the-art business communications system. Its alliance of features and facilities effectively improves communications for virtually any kind of organization.

To take full advantage of these advanced features and facilities there is a line of telephones, designed for ease of use in every situation.

Function descriptions that do not include speaking in the handset, are described off-hook, if nothing else is stated. Instead of pressing the "Clear-key", you can always replace the handset.

Some markets use differing codes for some functions. In this guide, all functions are described using the most common code for every specific function. As a note the markets and their differing code is shown.

The User Guide describes the facilities of the Dialog 3213 system telephone as it is programmed at delivery from the factory. There may be some differences in the way your phone is programmed. Please consult your system administrator if you need further information.

The latest version of this User Guide can also be downloaded from: <http://www.ericsson.com/enterprise/archive/manuals.shtml>

Note: *Dialog 3213 is a system telephone, i.e. it can only be used for an Ericsson private branch exchange that supports this type of telephone.*

ERICSSON MAKES NO WARRANTY OF ANY KIND WITH REGARD TO THIS MATERIAL, INCLUDING, BUT NOT LIMITED TO, THE IMPLIED WARRANTIES OF MERCHANTABILITY AND FITNESS FOR A PARTICULAR PURPOSE. Ericsson shall not be liable for errors contained herein nor for incidental or consequential damages in connection with the furnishing, performance or use of this material.

Hereby, Ericsson Enterprise AB, declares that this telephone, is in conformity with the essential requirements and other relevant provisions of the European R&TTE directive 1999/5/EC. Please refer to: <http://www.ericsson.com/sdoc>.

EN/LZT 103 24 R1A

© Ericsson Enterprise AB 2002

All rights reserved. No parts of this publication may be reproduced, stored in retrieval system, or transmitted in any form or by any means, electronic, mechanical, photocopying, recording or otherwise, without prior written permission of the publisher.

Table of Contents

	page
Description	4
Free Seating (optional)	7
Incoming Calls	9
Outgoing Calls	12
During Calls	15
When You Receive a Busy Tone	21
Call Forwarding	25
Internal Messages	37
Voice Mail	40
Information	43
Abbreviated Numbers	45
Call Metering	50
Group Facilities	52
Other Useful Facilities	54
Paging (optional)	65
Authority	70
Programming and Adjustments	76
Audible Signals	87
Visible Signals	89
Display Information	90
Option Unit/Vocabulary	94
Installation	95
Index	98

Description

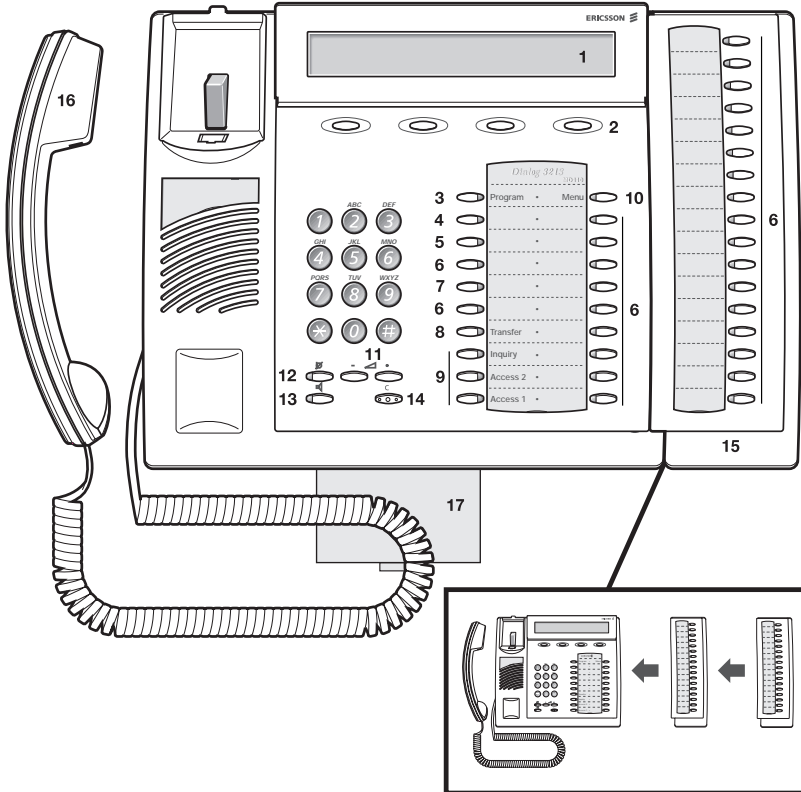

- 1 Display**
3x40 characters. See section [“Display Information”](#) on page 90.
- 2 Soft keys**
The functions depend on the traffic state. When you are requested to “(see display)”, press the required key to access the function.
- 3 Programming**
See section [“Programming and Adjustments”](#) on page 76.

- 4 Callback**
See section [“When You Receive a Busy Tone”](#) on page 21. Function can be removed or moved to other programmable function key by system administrator.
- 5 Diversion (follow-me)**
See section [“Call Forwarding”](#) on page 25. Function can be removed or moved to other programmable function key by system administrator.
- 6 Programmable function keys**
See section [“Programming and Adjustments”](#) on page 76.
- 7 Programmable function key/Headset key**
Normally a programmable function key as described at 6. With Option unit DBY 410 02 (optional accessory) installed under the telephone, the key is dedicated to be programmed by the system administrator as the Headset key. See section [“Other Useful Facilities”](#) on page 54.
- 8 Transfer**
See section [“During Calls”](#) on page 15.
- 9 Triple access line**
For handling calls. Access 1 and 2 are available both for incoming and outgoing calls. Inquiry can only be used for outgoing calls.
- 10 Menu key**
When the telephone is in idle state, press to switch between “idle message” and soft key descriptions.
- 11 Volume control**
See section [“Programming and Adjustments”](#) on page 76.
- 12 Mute**
 - a To switch the microphone on or off during a call.
 - b To switch off the ringing signal in idle state or when ringing. See sections [“During Calls”](#) on page 15 and [“Audible Signals”](#) on page 87.
- 13 Loudspeaker on/off**
See section [“During Calls”](#) on page 15.
- 14 Clear**
To disconnect calls, exit a function or clear the display in programming. Can always be pressed instead of replacing the handset.
- 15 Optional key panel**
With 17 dual-function programmable keys. One or two panels can be connected.

16 Handset

Supplied with hearing aid function as standard.

Please note: *The handset may attract and retain small metal objects in the earcap region.*

17 Optional pull-out leaf for easy guide

See inside of the back cover.

Free Seating (optional)

The free seating function is used for persons who have an office extension number but no telephone set of their own. For example, flexible office workers, persons mostly working outside the office, etc. As a free seating user and working from the office, you logon to any free telephone set that temporarily will be assigned with your extension number and your system authorities.

To log on

*** 1 1 ***

Press



Enter the authorization code and press



Enter your telephone number and press



Press to finish the procedure

The display shows your telephone number.

Note: An earlier version of the free seating function use another procedure: To log on, press *** 1 0 *** extension No. **#**.

To log off

1 1

Press



Press to finish the procedure

Note: An earlier version of the free seating function use another procedure: To log off, press **# 1 0 #**.

Incoming Calls

Answer calls

A ringing signal and a flashing lamp indicate an incoming call.

On Access 1

Normally you will receive calls on the Access 1 line.



Lift the handset

On any other line key

Lift the handset



Press the flashing line key

Handsfree

Press the flashing line key

You are connected to the caller via the loudspeaker and microphone.



Press to terminate a handsfree call



On another extension

You can answer a call to a phone in another room:

Call the ringing extension

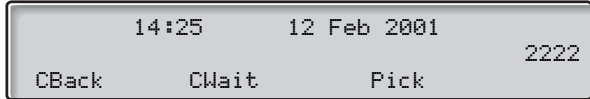

Note: *The display image might differ from the above.*

8 Press

Notes:

*You can also press **Pick** (see display) or **On-hold/Pick-up** (function key pre-programmed by you).*

*France press **4**; Sweden press **6***

Answer a second call during an ongoing call

If your telephone is pre-programmed with a “Free on 2nd access” key, you can receive another call, if this function is activated.



Free on 2nd Access

Press to activate / deactivate

When Free on 2nd access is active the lamp is lit.

Note: Function key pre-programmed by system administrator.

You have an ongoing call on Access 1, when the Access 2 key flashes to indicate a new incoming call:



Access 2

Press to answer

The first call is put on hold.



Access 1

Press to switch back to the first call

The second call is put on hold. You are connected to the first caller.



C

Press to terminate the connected call

Note: If the calling party has activated Call waiting, you can receive a second call even if Free on 2nd access is not activated.

Outgoing Calls

Make calls

How to make internal and external calls:



Lift the handset and proceed depending on call type:

Internal calls



Dial the extension number

External calls

0

Dial the digit or digits to get an external line

Dial tone.

Note: *The particular digit or digits used in your office, e.g. 0 or 00.*



Dial the external number

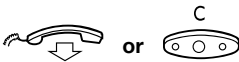

Press to end the call

Note: *If you receive a queue tone when the digit or digits to get an external line are dialled (optional function Least Cost Routing is used in the system), keep waiting. Once a line becomes free you will receive a dial tone. If a warning tone is heard, the selected line is marked "Expensive".*

Handsfree

With the handset on hook:



Dial the number

You are connected via the loudspeaker and microphone.



Press to terminate a handsfree call

Note: You can make your calls faster by using common abbreviated numbers and by using your own programmed abbreviated numbers. See section "[Abbreviated Numbers](#)" on page 45.

Individual external line

To make a call on a specific external line:

*** 0 ***

Press

 **#**

Dial the individual external line number and press



Dial the digit or digits to get an external line and the external number

Last external number redial

When you initiate an external call the system automatically stores all the dialled digits, irrespective of whether the call was successful or not.

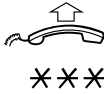

Lift the handset

Press to redial the saved number

The last external number is automatically redialled.

Notes:

*You can also press **Redial** (see display) or Last number redial (function key pre-programmed by you).*

*Finland and Sweden press *** * 0***

Save external number

When you make an external call, you can save the number in order to redial the same number easily. Any previously saved number is erased.

To save an external number:



Press before you finish the call

Note: *Function key pre-programmed by system administrator.*

Redial number



Lift the handset

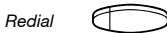

Press to redial the number

Note: *Function key pre-programmed by system administrator.*

During Calls

Group listening (loudspeaking)

This function lets other people in your room listen to your telephone conversation. You speak in the handset while the other party's voice is heard on the loudspeaker.



During an ongoing conversation:

Press to switch between loudspeaker and handset

When the key lamp is lit, the other party's voice is heard on the loudspeaker.

Note: You can adjust the volume, See section ["Programming and Adjustments"](#) on page 76.

From loudspeaking to handsfree



Replace the handset

Handsfree conversation.

From handsfree to loudspeaking

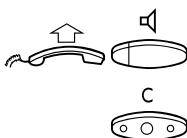

Lift the handset and press

C



Press to end the call

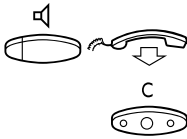

From handset to handsfree

Press and replace the handset
Handsfree conversation.

Press to end the call



From handsfree to handset

Lift the handset
Conversation via the handset.



Mute

Press to switch the microphone on or off
When the lamp is lit, the person on the line cannot hear what is being said in your room.



Inquiry

Press

Note: You can also press Access 2.



Call the second party

The first party is put on hold (the Access 1 key lamp flashes slowly). When the other party answers you can switch between the calls (refer back), transfer the call, create a conference and end one of the calls.



Press to end the inquiry call
The second party is disconnected.



Access 1

Press to return to the first party

Refer back

The key lamp flashes for the call put on hold.



Access 1

Press to put second party on hold

First party is connected.



Inquiry

Press to put first party on hold

Second party is connected.



Press to terminate the connected call

Transfer

You want to transfer an ongoing call.



Inquiry

Press



Call the second party



Transfer

Press before or after answer

The ongoing call is transferred.

Note: *If you have put more than one call on hold, the last call that was put on hold will be transferred. If the dialled extension is busy or transfer is not allowed, your phone will ring again.*

Conference

With this procedure you can include up to seven parties in a conference. Only the conference leader can admit participants. During the conference a tone will be heard every 15th second.

Note: *The conference tone might be disabled for your system.*

You have an ongoing conversation (Access 1) and want to establish a telephone conference. You will become the conference leader.



Inquiry

Press

Note: *You can also press Access 2.*



Call the second party

Wait for answer.

3

Press to establish a conference

Note: *You can also press: Conf (see display) or Conference (function key pre-programmed by you).*

Repeat the procedure to add more conference members



Replace the handset to leave the conference

On hold

You can temporarily put the ongoing call on hold. Calls put on hold can be resumed on your own telephone or another.

Individual

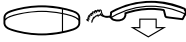

Press the ongoing call line key and replace the handset

The key lamp flashes slowly.



Press the line key again to resume the call

Common

8

Press

Notes:

*You can also press: **Pick** (see display) or On hold/Pick-up (function key pre-programmed by you).*

*France press **4**; Sweden press **6***



Replace the handset

The key lamp flashes slowly. If your number is multiple represented on other telephones, the key lamp that represents your number flashes slowly on these telephones.

To resume the call on your own extension:



Press the line key

To resume the call on another extension:



Call the extension where the call was put on hold

8

Press

Notes:

*You can also press: **Pick** (see display) or On hold/Pick-up (function key pre-programmed by you).*

If your number is multiple represented on the telephone, you can also press the key that represents your number.

*France press **4**; Sweden press **6***

Send caller identity code at transfer

When transferring a call you can send the caller's identity code or number to the receiver's display.

You have speech connection with an external party on Access 1.



Inquiry

Press to put the call on hold

Note: You can also press Access 2.

77

Press

⓪⓪⓪
⓪⓪⓪ #
⓪

Dial the caller's identity code or number and press

⓪⓪⓪
⓪⓪⓪
⓪⓪⓪
⓪

Call the second party



Transfer

Press before or after answer

The ongoing call is transferred with the caller's identity code or number.

Note: You can only use this function if the receiver's telephone is programmed to handle identity codes.

Dialling during a connected call

When calling interactive tele services, e.g. telephone banks, you need to use Dual Tone Multi Frequency (DTMF) signals. If your exchange is not already programmed to automatically convert your entered digits into DTMF signals, you need to activate the function during the call.

During an ongoing call:

9
⓪⓪⓪
⓪⓪⓪
⓪⓪⓪
⓪

Press and dial the requested digits

Entered digits are transferred as DTMF signals.

Notes:

You can also press **Tone** (see display).

Finland press **1** and dial the required digits.

When You Receive a Busy Tone

Busy extension or external line

If you call an extension and receive a busy tone or get no answer or all external lines are busy you can use these methods:

Automatic callback

If a called extension is busy or there is no answer:

6 Press

Notes:

You can also press: **CB**ack (see display) or **Callback** (function key pre-programmed by you).

France, Finland and Sweden press 5



Replace the handset to finish procedure

You are called back (recall ringing signal) when the ongoing call is finished or the next time a new call is finished. You have to answer within eight seconds, otherwise the Callback service is cancelled.



Lift the handset when you are called back

The system calls the extension.

Note: *Callbacks can be activated on several extensions at the same time. Callbacks from additional lines will recall on the Access 1 line.*

If all external lines are busy (after dialling the digit or digits to get a line):

6 Press

Notes:

You can also press: **CB**ack (see display) or **Callback** (function key pre-programmed by you).

France, Finland and Sweden press **5**



Dial the external number and press



Replace the handset to finish procedure

When an external line becomes free you will be called back (recall ringing signal). You have to answer within eight seconds, otherwise the Callback service is cancelled.



Lift the handset when you are called back

The system calls the external number.

Note: Only one Callback can be activated on a busy external line. Callbacks from additional lines will recall on the Access 1 line.

Cancel any single callback

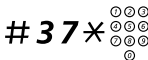

Press and dial the extension number

Note: To cancel a single Callback on a specific external line, dial the digit or digits to get a line instead of the extension number.

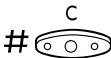

Press

Cancel all callbacks



Press



Press

Activate call waiting

If you urgently wish to contact a busy extension or external line, you can notify it by a call waiting signal.

5 Press

Notes:

You can also press: **Clwait** (see display) or Call waiting (function key pre-programmed by you).

France and Finland press **6**; Sweden press **4**

Keep handset off-hook. When the called extension or the external line becomes free, it will be called automatically.

Note: The call waiting function might be blocked for use on your extension (programmed by system administrator). If call waiting is not allowed you will continue to receive a busy tone.

Intrusion on a busy extension

You can intrude on an ongoing call on a busy extension.

4 Press

Notes:

You can also press: **Intr** (see display) or Intrusion (function key pre-programmed by you).

France and Sweden press **8**

Before the intrusion is executed a warning tone is sent to the parties in the ongoing call. A three party call is established and a warning tone is heard.

Note: The warning tone might be disabled for your system. The Intrusion function might be blocked for use on your extension (programmed by system administrator). If Intrusion is not allowed you will continue to receive a busy tone.

Intrusion on a busy external line

You can intrude on an ongoing call on a busy external line.

✖ 4 4 ✖



Press and dial the individual external line number

#



Press and dial the digit or digits to get an external line
Busy tone.

4

Press

Notes:

*You can also press: **Intr** (see display) or **Intrusion** (function key pre-programmed by you).*

*France and Sweden press **8***

Before the intrusion is executed a warning tone is sent to the parties in the ongoing call. A three party call is established and a warning tone is heard.

Note: *The warning tone might be disabled for your system. The Intrusion function might be blocked for use on your extension (programmed by system administrator). If Intrusion is not allowed you will continue to receive a busy tone.*

Call Forwarding

Diversion

If you do not want to be disturbed or will be out of the office, you can have all calls to your extension diverted to a pre-programmed answering position. During diversion you will hear a special dial tone and the diversion lamp indicates that your triple access line is diverted. You can still make calls as usual.

Diversion can be direct, on no answer, on busy or to another information service facility.

Note: *If your telephone is programmed with "Multiple Directory Diversion and Do not disturb" (ask your system administrator), Diversion is ordered and cancelled simultaneously on all lines.*

Order direct diversion from your own extension

The call is diverted to an individual position or up to three pre-determined common answering positions (depending on the type of the incoming call). Programmed by the system administrator.



Diversion

Press

Note: *Function key pre-programmed by system administrator. If you order diversion with the handset off-hook or the loudspeaker on, press the diversion key twice. You can also use the procedure below.*

*** 2 1 #**

Press

Note: *U.K. press * 2 #*



Press

Note: *Diversion can also be ordered and cancelled from the answering position, use the same procedure as in section "Internal follow-me" on page 28.*



Diversion

Cancel direct diversion from your own extension

Press

Note: Function key pre-programmed by system administrator. You can also use the procedure below.

2 1

Press

Note: U.K. press **# 2 #**



Press

Note: Diversion can also be ordered and cancelled from the answering position, use the same procedure as in section "[Internal follow-me](#)" on page 28.

Diversion when there is no answer

✖ 2 1 1 #

Press to order

Note: Finland and Norway press **✖ 6 1 #**

The incoming call is diverted after 3 signals.



Press

2 1 1

Press to cancel

Note: Finland and Norway press **# 6 1 #**



Press

Diversion when caller receives a busy tone

***212#**

Press to order

Note: *Finland and Norway press *67#*



Press

#212#

Press to cancel

Note: *Finland and Norway press #67#*



Press

Diversion to another information service facility

***218#**

Press to order



Press

#218#

Press to cancel



Press

Internal follow-me

All calls to your extension are diverted to an extension of your choice (within the private network). During follow-me you will hear a special dial tone and the diversion lamp indicates that your triple access line has follow-me. You can still make calls as usual.

Note: If your telephone is programmed with "Multiple Directory Diversion and Do not disturb" (ask your system administrator), Internal follow-me is ordered and cancelled simultaneously on all lines.

Order from your own extension



Lift the handset



Press and dial the answering position number

Note: Function key pre-programmed by system administrator.

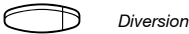

Press to order



Replace the handset

Note: You can also use the procedure below.

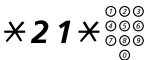

Press and dial the answering position number

Note: U.K. press *2* No.

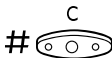

Press



Diversion

Cancel from your own extension

Press

Notes:

Function key pre-programmed by system administrator.

You can also use the procedure below.

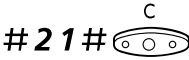

Press

Note: U.K. press # 2 #

Redirect from answering position

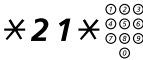

Press and dial your own extension number

Note: U.K. press × 2 × No.



Press and dial the diversion number

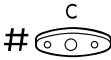

Press to redirect

Calls are diverted to the answering position.

Note: Internal follow-me must be ordered from your own extension before you can redirect from answering position.

Cancel from answering position

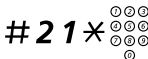

Press and dial your own extension number

Note: U.K. press # 2 × No.

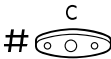

Press

External follow-me

If external follow-me is allowed you can have all calls to your extension diverted to an external number of your choice. A special dial tone will be heard. You can still make calls as usual.

* 2 2 #

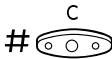

Order

Press and dial the digit or digits to get an external line and the external number

Press

Cancel

Press

Note: Function key pre-programmed by system administrator. You can also use the procedure below.



Diversion

2 2

Press



Press

Bypass diversion

If bypass diversion is allowed from your extension, you can bypass an activated diversion/follow-me on a specific extension.

* 6 0 *



Press and dial the extension number

#

Press and wait for answer

Personal number (optional)

With this function you can be reached on your normal office telephone number even if you are in another room, out of the office, at home, etc. Depending on the functionality of your office exchange, you can have either one individual single search profile or you can choose between five individual search profiles. A search profile can be designed to fit the situation, i.e. In the office, On travel, At home, etc. Both internal or external telephone numbers can be used in a profile.

On your request, the search profiles are programmed or modified by the system administrator. See section [“To design and order your search profiles”](#) on page 33.

When the function is activated, incoming calls are transferred to different telephones or back-up services in your decided order. If an answering position in the profile is busy, the call can be transferred to another predefined position in the profile, i.e. Voice mail or a colleague. You can activate the function from your own office telephone or when out of the office, by using the Direct Inward System Access function (DISA).

To activate or change to another profile from your office telephone

✖ 10 ✖

Press

(1 – 5)

Dial the search profile digit

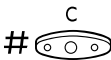

Press

The display shows the chosen search profile digit.

Note:

You can also activate and change to another profile by programming one function key/search profile (the function keys has to be pre-assigned by your system administrator). When the search profile is active the key lamp is on. See section [“Programming and Adjustments”](#) on page 76.

If the operator is included in the activated profile as an answering position, always inform the operator if you are absent. Use the Absence information function or call the operator. If Voice Mail is included in the activated profile, always update your greeting with absence information.

1 0



To cancel from your office telephone

Press

Press

Note: If you have activated a profile via a function key, you can press this key instead of using the procedure above.

To activate or change to another profile from an external telephone

The external telephone must be of push button type provided with hash (#) and star (*) keys or a mobile telephone adapted for dial tone pulses (DTMF).



Call the DISA function at your office

Dial tone.

*** 7 5 ***

Press



Enter the authorization code and press



Dial your own extension number and press

Dial tone.

*** 1 0 ***

Press



Dial your own extension number and press

(1 – 5)

Dial the search profile digit



Press and replace the handset

Note: If the operator is included in the activated profile as an answering position, always inform the operator if you are absent. Use the Absence information function or call the operator. If Voice Mail is included in the activated profile, always update your greeting with absence information.

To cancel from an external telephone

The external telephone must be of push button type provided with hash (#) and star (*) keys or a mobile telephone adapted for dial tone pulses (DTMF).

**Call the DISA function at your office**

Dial tone.

*** 7 5 ***

Press



Enter the authorization code and press



Dial your own extension number and press

Dial tone.

1 0 *

Press



Dial your own extension number and press



Replace the handset

To design and order your search profiles

The search profiles are installed or changed by the system administrator. In order to set up your profiles, copy the setting form, fill in your new or changed profiles and give it to your system administrator.

Note: *If Personal Screen Call Server is connected to your system, you can edit the profiles via your Intranet. See instructions for the server!*

Important notes when designing your search profiles:

- Avoid a ringing time longer than 45 seconds for your profiles
Usually the caller hangs up after 3-6 ringing signals. If you need a longer ringing time, the maximum time is 60 sec.
- Consider the time you need to react and answer on each answering position in your profiles
You might need up to 15 seconds to react and answer on a desk or cordless telephone and 20–25 seconds for a mobile telephone.
- There must be an answering position at the end of every profile (voice mail or operator/secretary)
If not, calls might end up unanswered.
- Consider what should happen when you are busy on a telephone
The available options are:
 - *Activate Free on 2nd (if available)*
 - *Diversion to Voice mail*
 - *Diversion to the operator*
- *If an answering machine, a FAX or other answering service is used as an early answering position, it might interrupt the searching*
Disconnect the answering service, or design the ringing times so they do not affect the searching.
- If your system admits just one single personal profile, design the profile only with your 2–3 most frequently used positions
If you add more numbers, there is a risk that the caller hangs up before a late position is called.
- If your system admits 1–5 personal profiles, design the different profiles to fit your most used positions
Make sure you use as few answering positions as possible for each profile. Profile examples:
 - *In office*
 - *At home*
 - *On travel*
 - *Absent/not reachable*

Example:

How to fill in your setting form for search profiles:

Profile 1

In office

Search order	Type of telephone or answering position*	Telephone number	Ringling time (seconds)
1	Desk	1234	10
2	Cordless	5234	15
3	Voice Mail		

* Examples: Desk, Cordless, Mobile, External, Voice Mail, Operator, etc.

Profile 2

At home

Search order	Type of telephone or answering position*	Telephone number	Ringling time (seconds)
1	External	222222	20
2	Mobile	0706666666	25
3	Voice Mail		

Setting form for search profiles

Name:

Department:

Telephone No:

Account:

Profile 1

.....

Search order	Type of telephone or answering position*	Telephone number	Ringling time (seconds)
1			
2			
3			
4			

* Examples: Desk, Cordless, Mobile, External, Voice Mail, Operator, etc.

Profile 2

.....

Search order	Type of telephone or answering position*	Telephone number	Ringling time (seconds)
1			
2			
3			
4			

Profile 3

.....

Search order	Type of telephone or answering position*	Telephone number	Ringling time (seconds)
1			
2			
3			
4			

Profile 4

.....

Search order	Type of telephone or answering position*	Telephone number	Ringling time (seconds)
1			
2			
3			
4			

Internal Messages

Manual message waiting (MMW)

If the called extension does not answer you can initiate a message waiting indication on that extension (if this function is allowed).



Message

Answer

Press

Note: *Function key pre-programmed by system administrator.*

A call is initiated to the extension that requested message waiting.



Program

Press

The program key lamp turns on and all other lamps turn off.



Message

Press

Note: *Function key pre-programmed by system administrator.*

The number that requested message waiting is shown in the display.



Program

Press to finish procedure

Cancel MMW at your own extension

3 1

Press



Press

Order MMW to another extension

* 3 1 *

Press



Dial the extension number

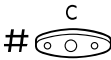

Press

The message waiting key lights up on the called extension.

Cancel MMW to another extension

3 1 *

Press



Dial the extension number

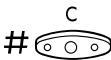

Press

Message waiting (optional)

If assigned this function and your telephone is diverted to an interception computer, a function key (programmed by the system administrator) will flash when there are messages stored for you in the computer. The messages will be printed out on a printer connected to the computer.



Message

To print out messages

Press

The display shows the identity of the computer and the number of messages stored for you.

If you find that the notification of message waiting is intrusive or you want to shut off the notification:

9 1 # *

Press

Acknowledgement tone.

Voice Mail

Integrated voice mail (optional)

This function allows you to leave a voice message to the caller when you are unable to answer calls, e.g. when out of office, in a meeting, etc. Then the caller can leave a message in your mailbox. When back in office you can enter your mailbox and listen to received messages.

You can choose to divert all incoming calls to your mailbox, or calls when there is no answer, or calls when your telephone is busy.

When you enter your mailbox, you will hear recorded instructions how to handle listening, recording, storing and deleting messages, and how to change your security code.

To activate and deactivate your mailbox

For all incoming calls:

See “[Call Forwarding](#)” on page 25, section “[Internal follow-me](#)” on page 28 (function code 21). Use the number to the voice mail system as the “answering position number”.

When incoming calls get no answer:

See “[Call Forwarding](#)” on page 25, section “[Diversion](#)” on page 25 when there is no answer (function code 211).

When incoming calls get a busy tone:

See “[Call Forwarding](#)” on page 25, section “[Diversion](#)” on page 25 when caller receives a busy tone (function code 212).

To enter your mailbox

From your office telephone:

**Dial the number to the voice mail system**

Note: *If a function key is programmed for your mailbox and the key lamp is lit or flashing (= a new message is received), you can also press this key.*

If you are asked to enter your security code:

**Enter your security code**

Code at delivery = your extension number.

From another telephone:

**Dial the number to the voice mail system**

If you are asked to enter your security code (the used telephone has a mailbox of its own):

#**Press****Enter your mailbox number**

(normally your office extension number)

**Enter your security code (if required)****To enter someone else's mailbox****Dial the number to the voice mail system**

If you are asked to enter your security code (the used telephone has a mailbox of its own):

#**Press****Enter the mailbox number**

(normally the office extension number of the person served)

**Enter the security code of the person served (if required)**

To handle the mailbox

Recorded information on the line informs about the number of new and stored messages. If you have too many messages stored, you will first be asked to delete saved messages.

Recorded instructions ask you to press different digits in order to listen to caller's messages, record your own greetings, change your password or exit your mailbox, etc.

The following diagram gives an overview of the mailbox system and the digits to be used.

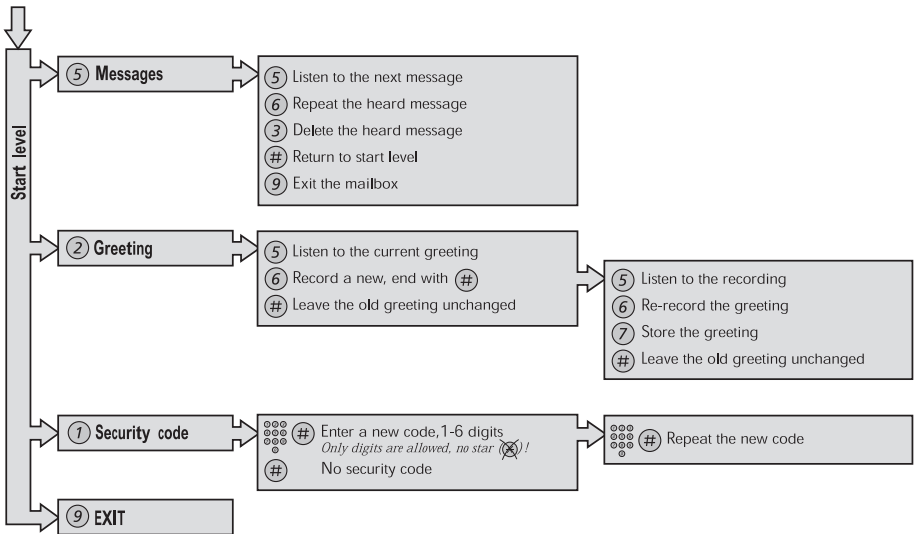

Information

Absence information (optional)

To be used during absence to inform callers about the reason and time or date of your return. If you are authorized, you can also enter absence information on another extension from your own extension.

Order

Example: Back on September 15th (=0915).

*** 2 3 ***

Press

(0 – 9)

Enter the absence code

Note: *The absence codes consist of one digit which depends on the system connected to the exchange. Contact your system administrator regarding your available absence codes.*

*** 0 9 1 5**

Press and enter the date (MMDD) or time (HHMM) of your return

Note: *If no return time or date is needed, this step can be excluded.*



Press

The display shows the reason, and if entered, time or date of return.

2 3

Cancel

Press

Press

The programmed information is erased.

Order for another extension

*** 2 3 0 ***
Press



Dial the extension number and press

(0 - 9)
Enter the absence code

*** 0 9 1 5**
Press and enter the date or time of the other person's return



Press

The display on the other person's extension shows the reason, and if entered, time or date of return.

Cancel for another extension

2 3 0 *
Press



Dial the extension number and press

Note: If the special dial tone is received, the authorization code for the other extension is required. Add the code and press # before pressing the Clear key.

Press

Abbreviated Numbers

Common abbreviated numbers

By using abbreviated numbers, you can make calls simply by pressing a few keys. The common abbreviated numbers consist of 1–5 digits and are stored in the exchange (by the system administrator).



Lift the handset and dial the common abbreviated number

Individual abbreviated numbers

You can program up to ten frequently used telephone numbers on the digit keys 0–9 and use them as individual abbreviated numbers (if this function is allowed).

Note: *In Finland up to nine numbers, keys 1–9.*

To use

**** (0–9)**

Press and dial the relevant digit

Note: *Finland press ** (1–9); Sweden press (0–9) #*

Program and alter individual abbreviated numbers

✳ 5 1 ✳ (0 - 9)

Press and dial selected digit

Note: Finland press ✳ 5 1 ✳ (1 - 9)



Press and dial the telephone number

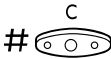

Press

Note: The programmed number may consist of a maximum of 20 digits plus a "✳", which indicates the second dial tone from the public network. The display only shows the last 20 characters in a number.

Erase one programmed number

5 1 ✳ (0 - 9)

Press and dial selected digit

Note: Finland press # 5 1 ✳ (1 - 9)



Press

Erase all programmed numbers

5 1

Press



Press

Dial-by-name (optional)

By use of the Integrated Telephone Directory you can search for a name, group, operator, etc. via your display and then call the wanted person or group by use of a soft-key below the display.

Dir

Press (see display)

The display shows:

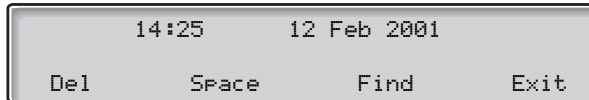

Del

Press to delete the last entered character (see display)

Space

Press to enter a space (see display)

Find

Press to search using the entered characters (see display)

Exit

Press to return to the previous menu (see display)

Use the key pad to enter the characters of the name. The characters above the keys show the key to be pressed.

Example:

Select characters by pressing digits repeatedly. The cursor is moved automatically when you stop pressing.



Press a digit

1 time	result	A
2 times	result	B
3 times	result	C

When the requested character is shown on the display, wait for the cursor to move to the next place.

The name must be entered as follows:

Family name - Space - Name

It is not necessary to enter all the characters, just as many to get as close as possible to the requested name when you start to search.

Note: *If you want to specify the person's first name, you must enter the full family name before you can enter a space.*

Example:

To search for Bob Smith:

7 7 7 7

Press for S

6

Press for m

4 4 4

Press for i

The display shows:

Smi	14:25	12 Feb 2001	
Del	Space	Find	Exit

Find

Press to find (see display)

If SMI was sufficient to find Bob Smith, the display shows:

Smith Bob			54321
Up	Space	Call	Back

If SMI gives a name close to Bob Smith, e.g. Ann Smith, scroll down until you find the requested name.

Up

Press to scroll up trough the name list (see display)

Down

Press to scroll down trough the name list (see display)

Call

Press to dial the number displayed (see display)

Back

Press to return to the previous menu (see display)

If there is additional information in the directory for the name being displayed, this is shown under the name, e.g. company, country, etc.

The display will inform if no name matches your search and show the name alphabetically preceding the entered one.

Dial by a function key

Head office



Press the function key

Program

Both telephone numbers and function codes can be programmed on a function key.



Program

Press

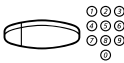

Press the selected function key and dial the telephone number or function code



Press the function key again



Program

Press to finish programming

Assign the key.

Verify and erase programmed number



Program

Press



Press the selected function key

The stored number is shown on the display.

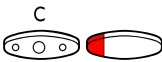

Press if you want to erase the stored number

The stored number is erased.



Program

Press

Call Metering

Charging information

Charging information for your call can be shown in the local currency in the display.

	14:25	12 Feb 2001	
Cost in £	3.25		2222
Tones		Cost	Time

Cost

Press to display or hide the cost indication (see display)

Note: *The cost indication is automatically displayed for all charged calls, when the function is activated.*

Timer

You can measure the elapsed time of your call.

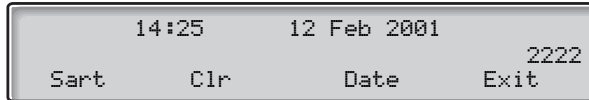

- Time** **Press to activate the timer (see display)**
- Start** **Press to start the timer function (see display)**
The display changes and the elapsed time is shown.
- Stop** **Press to stop the timer function (see display)**
- Exit** **Press to exit the timer function (see display)**

Note: *Timer can be activated when your telephone is idle, ready for dialling, during an outgoing call or when in speech connection.*

Other functions

These functions are also available, during timer mode:

- Date** **Press to show date (see display)**
- Time** **Press to display time measurement (see display)**
- Clr** **Press to clear time measurement (see display)**

Group Facilities

Call pick-up group

People working in a team can have their telephones programmed by the system administrator to form Call Pick-up groups.

In a Call Pick-up group, any member can answer any individual call to group members.

8 Press to answer

Notes:

*You can also press **CUF** (see display).*

One Call Pick-up group can serve as an alternative to another group. Calls to the alternative group can only be answered when there are no calls to your own group.

*Finland and Sweden press **0***

Common bell group

Calls are signalled on a common bell.

8 Press to answer

Notes:

*You can also press **CUF** (see display).*

*Finland and Sweden press **0***

Group hunting

As a member of a group of extensions that is called by a common number, you can temporarily leave the group.

✖ 2 1 ✖ 

Press and dial your own extension number

Note: U.K. press ✖ 2 ✖ No.



Press

To re-enter the group

2 1

Press

Note: U.K. press # 2 #



Press

If you are authorized you can divert all calls to a group to another extension or group:

✖ 2 4 ✖

Press



Dial the number of the group to be diverted and press



Dial the extension number of the new answering position



Press

To cancel the diversion:

2 4 ✖

Press



Dial the number of the group that has been diverted



Press

Other Useful Facilities

Account code (optional)

This function is used to charge a call to an account number or to prevent unauthorised calls from your telephone. The account code can have 1 to 15 digits.

*** 6 1 ***

Press

Note: *Finland and Norway press * 7 1 **

⓪⓪⓪
⓪⓪⓪ #
⓪⓪⓪
⓪

Enter the account code and press

Dial tone.

Note: *You can also press AcCo (see display), enter the account code and press Enter (see display).*

⓪⓪⓪
⓪⓪⓪
⓪⓪⓪
⓪

Dial the digit or digits to get an external line and the external number

**Access****Ongoing external call**

When used to charge a call it is also possible to connect an ongoing external call to an account code. During the call:

Press the line key to put the ongoing call on hold*** 6 1 *****Press****Note:** *Finland and Norway press * 7 1 ****Enter the account code and press**

Dial tone.

Note: *You can also press **AcCo** (see display), enter the account code and press **Enter** (see display).***Access****Press the line key for the call put on hold****Immediate speech connection**

You automatically answer a call without lifting the handset or pressing any keys. The function can be permanently active or activated by use of a function key (programmed by system administrator).

Permanently active

Program the ringing option with “Immediate speech connection with single tone burst”, option 6, on the Access line key. See section “[Programming and Adjustments](#)” on page 76.

Activated on a function key**Press to order or cancel****Note:** *Function key pre-programmed by system administrator.*

The incoming call is signalled with a tone burst. When the key lamp is lit you can use this function.

Automatic answer

General cancellation

The following features can be simultaneously cancelled:

- Callback (all Callbacks are cancelled).
- Diversion/Internal and External Follow-me.
- Manual message waiting/Message diversion.
- Do not disturb.
- Flexible night service.

0 0 1



Order

Press

Press

Night service

When the exchange is in night service mode, all your incoming calls to the operator are transferred to a selected extension or group of extensions. The exchange is equipped with four different night service modes:

Common night service

All incoming calls to the operator are transferred to one specific extension. Answer the call in the normal way.

Individual night service

Selected external calls to the operator are transferred to one specific extension. Answer the call in the normal way.

Universal night service

All incoming calls to the operator are transferred to a universal signalling device, e.g. the common bell. Answer the call as described in section “[Common bell group](#)” on page 52.

Flexible night service

This function permits you to order an external line and connect it directly to your telephone. Ask your operator for the external line numbers.

To order flexible night service

✳ 84 ✳



Press and dial the digit or digits to get a line

✳



Press and dial the external line number



Press

Cancel

84



Press and dial your own extension number



Press

Hot line

Ask your system administrator if you require this function.

Delayed hot line

When the handset of the delayed hot-line telephone is lifted or when the line key is pressed, a timer is started. If no digit is pressed before time out, a call is automatically generated to a specific extension or external line. If a digit is pressed before time out the telephone works as an ordinary telephone.

Note: *This function is only available in newer versions of the telephone exchange.*

Direct hot line

The same function as described above, but no delay. Only hot line calls can be placed from this line. To be used e.g. as alarm phone, door phone etc.

Alarm extension

An extension can be programmed by system administrator as an alarm extension. A call to an alarm extension obtains automatic intrusion if the extension is busy. Up to seven calling parties may be connected at the same time.

Emergency state

In the event of an emergency the operator can switch the exchange into emergency state, during which only pre-programmed extensions are permitted to make calls.

Data communication

Your telephone can be used together with a PC as an integrated voice and data terminal. Contact your system administrator if you require this function.

Additional directory number

You can be assigned (programmed by system administrator) one or more additional directory numbers (lines) on free function keys.

To answer, make calls and use functions on the additional directory lines, use the same procedure as for triple access lines if nothing else is stated. However, you have to press the additional line key after lifting the handset.

Example:

To make a call on an additional directory line:

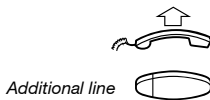

Lift the handset

Press

Note: Function key pre-programmed by system administrator.



Dial the extension number

Multiple represented directory number

Your extension number can be programmed on a dedicated key on other system telephones, i.e. the number is “represented” on these telephones.

This means that incoming calls to your extension can be answered on any of these other telephones by just pressing the dedicated key. The dedicated key can also be assigned the possibility to call your extension when pressed. This function has to be programmed by your System Administrator.

Malicious call tracing

If you are disturbed by malicious external incoming calls, you can request a number tracing from the network provider.

You can invoke tracing during or after an ongoing conversation. The external line can be held for a limited period of time.

Order

During an ongoing conversation:

Mal

Press (see display)

Note: You can also press *Mal. Call Tracing* (function key pre-programmed by system administrator).

The system acknowledges with different tones whether the tracing request was accepted or rejected.

Headset

If your telephone is equipped with Option unit DBY 410 02, the following headset functions are available.

Note: How to install Option unit and headset, see installation instruction provided with the Option unit.

Activate/Deactivate the headset



Headset

Press the headset key to activate/deactivate the headset

Note: Function key pre-programmed by system administrator.

See section “[Description](#)” on page 4. All calls can be handled via the headset.

Answer calls

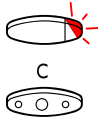

Press the flashing line key to answer

Press to terminate a headset call

Make calls

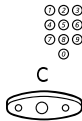

Dial the number

Press to terminate the call

Headset to handset



Lift the handset

Handset to headset



Headset

Press the headset key

Note: *Function key pre-programmed by system administrator.*



Headset with loudspeaking

Press to toggle between headset with or without loudspeaking



Headset to handsfree

Press



Headset

Press the headset key

Note: Function key pre-programmed by system administrator.



Headset

Handsfree to headset

Press the headset key

Note: Function key pre-programmed by system administrator.

Direct Inward System Access (DISA) (optional)

If you are assigned to use this function and you are working externally, you can call your office and get access to an external line in order to make business calls. The business call will be charged your office extension number or an account number. You will just be charged for the call to the office.

The external telephone must be of push button type provided with hash (#) and star (*) keys or a mobile telephone adapted for dial tone pulses (DTMF).

After a completed DISA call you must hang up before a new DISA call can be made.

Depending on the type of authorization code and if an account code is used, different procedures must be used:

With common authorization code

⓪⓪⓪
⓪⓪⓪
⓪⓪⓪
⓪

Call the DISA function at your office

Dial tone.

*** 7 2 ***

Press

⓪⓪⓪
⓪⓪⓪
⓪⓪⓪
⓪

Enter the authorization code and press

Dial tone.

⓪⓪⓪
⓪⓪⓪
⓪⓪⓪
⓪

Dial the external number

With individual authorization code

⓪⓪⓪
⓪⓪⓪
⓪⓪⓪
⓪

Call the DISA function at your office

Dial tone.

*** 7 5 ***

Press

⓪⓪⓪
⓪⓪⓪
⓪⓪⓪
⓪

Enter the authorization code and press

⓪⓪⓪
⓪⓪⓪
⓪⓪⓪
⓪

Dial your own extension number and press

Dial tone.

⓪⓪⓪
⓪⓪⓪
⓪⓪⓪
⓪

Dial the external number

Name and number log (optional)

With this function all unanswered calls to your telephone will be logged. By use of the soft keys under the display you can browse the log, make calls to logged numbers and delete logged numbers.

A function key must be programmed by the system administrator. The key lamp is switched on and will flash when new unanswered calls have been logged, since last time the key was activated.

Your telephone must be idle and unlocked to be able to browse the log.

To browse the number log

Number log



Press

Note: *Function key pre-programmed by system administrator.*

The key lamp is switched off and the display shows the number of stored numbers, time, date, name and number of the last unanswered call:

Unanswered calls:2			
14:25	12Feb 2001	Bob Smith	12345
Next	Del	Call	Exit

Next **Press to show the next logged number (see display)**

Del **Press to delete the displayed number (see display)**

Call **Press to call the displayed number (see display)**

Exit **Press to exit (see display)**

Paging (optional)

Persons equipped with a wireless paging receiver or assigned to a lamp signal, can be paged from a telephone set. Depending on the type of paging system it is possible to send digit messages or voice messages to the paged person.

Paging can also be initiated and answered during an ongoing call. Make an Inquiry call and proceed according to the appropriate procedure for the type of connected paging system. You can then either return to the ongoing call or transfer the paging call to the person that was put on hold. If this person is an external subscriber, your exchange must be programmed for this function.

If you receive a congestion tone when paging, this indicates that the paged person has his paging receiver in the charging rack and is probably out of the office.

Paging receivers without a display and paging via lamp signals

To initiate

When there is no answer or a busy tone, keep the handset off hook:

7

Press

Wait for an answer with the handset off hook.

If you want to start paging without calling the person:

*** 8 1 ***

Press

⊙⊙⊙
⊙⊙⊙
⊙⊙⊙
⊙

#

Dial the extension number and press

Wait for an answer with the handset off hook.

To answer

From any telephone within the system and within the predetermined paging time:

*** 8 2 ***

Press

⊙⊙⊙
⊙⊙⊙
⊙⊙⊙
⊙

#

Dial your own extension number and press

Or if only one paging call is permitted at the time:

*** 8 2 #**

Press

Paging receivers with a display

To initiate

When there is no answer or a busy tone, keep the handset off hook:



Press and replace the handset

Wait for the paged person to call back.

If you want to start paging without calling the person:

*** 8 1 ***



Press

Dial the extension number and press

Wait for the acknowledgement tone.



Replace the handset

Wait for the paged person to call back.

If you want to send a digit message code:

*** 8 1 ***



Press

Dial the extension number and press



Dial the message code (1–10 digits) and press

Wait for the acknowledgement tone.



Replace the handset

If expected, wait for the paged person to call back.

To answer

From the nearest telephone within the system: Call the extension number shown in the display of your paging receiver. If zeros are shown it indicates that you are being paged from an external subscriber. To answer:

*** 8 2 ***
⊙ ⊙ ⊙
⊙ ⊙ ⊙ ⊙
⊙ ⊙ ⊙ ⊙
⊙

Press

Dial your own extension number and press

Or if only one paging call is permitted at the time:

*** 8 2 #**

Press

If a message code is shown in the display, take the appropriate action.

Paging receivers with voice message

To initiate

When there is no answer or a busy tone, keep the handset off hook:

7

Press

Leave your message after the tone. Just before the predetermined speech time is ended, a warning tone will be heard.

If you want to start paging without calling the person:

*** 8 1 ***

Press

⊙ ⊙ ⊙
⊙ ⊙ ⊙ ⊙
⊙ ⊙ ⊙ ⊙
⊙

Dial the extension number and press

Leave your message after the tone. Just before the predetermined speech time is ended, a warning tone will be heard.

To answer

If your paging receiver has bothway voice connection, press the answer button to speak. If no bothway connection exists, take the appropriate action according to the message or answer the paging in the same way as paging without a voice message.

Alarm paging

To initiate

*** 8 1 0 ***

Press

⓪⓪⓪
⓪⓪⓪ #
⓪

Dial the extension number and press

Wait for the acknowledgement tone.



Replace the handset

If you want to send an alarm message code:

*** 8 1 0 ***

Press

⓪⓪⓪
⓪⓪⓪ *
⓪

Dial the extension number and press

⓪⓪⓪
⓪⓪⓪ #
⓪

Dial the message code (1–5 digits) and press

Wait for the acknowledgement tone.



Replace the handset

To acknowledge an alarm

You must acknowledge the alarm to be terminated:

*** 8 2 0 ***

Press

⓪⓪⓪
⓪⓪⓪ #
⓪

Dial your own extension number and press

To acknowledge an alarm for another extension:

*** 8 2 0 ***

Press

⓪⓪⓪
⓪⓪⓪ *
⓪

Dial the other extension number and press

⓪⓪⓪
⓪⓪⓪ #
⓪

Dial your own extension number and press

Authority

Data privacy

Data privacy allows you to make a call without any disturbances, i.e. intrusion. This function is automatically cancelled when the call is finished.



Order

Lift the handset

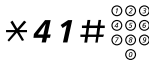

Press and dial the number

Do not disturb, DND

When you activate DND, calls to your extension are not indicated. Outgoing calls can be made as usual.

DND

Press to activate or deactivate DND (see display)

Note: You can also press DND (function key pre-programmed by system administrator) or use the procedure below.

***27#**

Dial to activate

Special dial tone.

or

#27#

Dial to deactivate



Press to finish activation/deactivation

Note: If your telephone is programmed with "Multiple Directory Diversion and Do not disturb" (ask your system administrator), DND is ordered and cancelled simultaneously on all lines.

Group do not disturb

If your extension is defined as a master extension (programmed by system administrator), you can mark a group of extensions as Group do not disturb. The group can be bypassed by you.

Order

*** 2 5 *** 

Press and dial the group number

Note: *Germany and South Africa press * 2 8 * No.*

#

Press

Special dial tone.



Press

Cancel

2 5 * 

Press and dial the group number

Note: *Germany and South Africa press # 2 8 * No.*



Press

Bypass

*** 6 0 *** 

Press and dial the extension number

#

Press

The call is made to the specified extension in the group.

Authorization code, common (optional)

If you are assigned to use a common authorization code (1 to 7 digits) you can temporarily change any used telephone within the exchange to the authority level connected to this code. You can use the code for one call only or you can open the phone for some calls and lock it when leaving the phone.

To use for a single call

*** 7 2 ***

Press

⓪⓪⓪
⓪⓪⓪ #
⓪

Enter authorization code and press

Verification tone.

Note: You can also press **Auto** (see display), enter the code and press **Enter** (see display).

⓪⓪⓪
⓪⓪⓪
⓪⓪⓪
⓪

Dial the digit or digits to get an external line and the external number

To open an extension for some calls

7 3 *

Press

⓪⓪⓪
⓪⓪⓪ #
⓪⓪⓪
⓪

Enter authorization code and press

Verification tone.

Note: You can also press **Open** (see display), enter the code and press **Enter** (see display).

To lock an extension

*** 7 3 ***

Press

⓪⓪⓪
⓪⓪⓪ #
⓪⓪⓪
⓪

Enter authorization code and press

Verification tone.

Note: You can also press **Lock** (see display), enter the code and press **Enter** (see display).

Authorization code, individual (optional)

If you are assigned to an individual authorization code (1 to 7 digits, affiliated to your own extension) you can lock your own extension to a common authority level, e.g. when out of the office. You can also temporarily change any other used telephone within the exchange to the same authority level as you have on your own phone.

The individual code can be changed from your own extension.

To lock your telephone

✳ 7 6 ✳

Press

⓪⓪⓪
⓪⓪⓪ #
⓪⓪⓪
⓪

Enter authorization code and press

Verification tone.

Note: You can also press **Lock** (see display), enter the code and press **Enter** (see display).

To make calls with your authority level when your telephone is locked

✳ 7 5 ✳

Press

⓪⓪⓪
⓪⓪⓪ #
⓪⓪⓪
⓪

Enter authorization code and press

Verification tone.

Note: You can also press **Auto** (see display), enter the code and press **Enter** (see display).

⓪⓪⓪
⓪⓪⓪
⓪⓪⓪
⓪

Dial the digit or digits to get an external line and the external number

To open your telephone

7 6 *

Press



Enter authorization code and press

Verification tone.

Note: You can also press **Open** (see display), enter the code and press **Enter** (see display).

To assign your own authority level to another telephone

* 7 5 *

Press



Enter authorization code and press

Verification tone.

Note: You can also press **Auto** (see display), enter the code and press **Enter** (see display).



Dial your own extension number and press

Verification tone.



Dial the digit or digits to get an external line and the external number

To change your individual authority code

* 7 4 *

Press



Enter old authorization code and press



Enter new authorization code and press

Verification tone.

Programming and Adjustments

Programming of functions

Frequently used functions and telephone numbers can be programmed on the function keys for easy access. When you want to use the function, just press the key. Certain functions must be pre-programmed by the system administrator.

Program or change a function



Program

Press



Press selected function key

Note: *If the key is already programmed, the number or function will be displayed.*



Enter telephone number or a function code according to the list on the next page

Note: *If a wrong number is entered, press the Clear key to erase it, and then enter the number again.*



Press the function key again



Program

Press to finish programming

Remove the transparent cover and write the function name or telephone number beside the key.

Note: *To erase a programmed function, press the Clear key, instead of the telephone number or function code, in the sequence above.*



Program

Verify a programmed number or function

Press



Press selected function key

The stored number or function is displayed.



Program

Press

Functions and required data

<i>Function</i>	<i>Function code or Associated number</i>			
	Most common	Finland	France	Sweden
Call pick up:				
Group	8		4	6
Individual	No. + 8		No. + 4	No. + 6
Call waiting	5	6	6	4
On hold, common	8		4	6
Conference	3			
Dial by a function key	Extension No.			
Flexible night service	* 8 4 * 0 * + External line number + #			
Intrusion on busy extension	4		8	8
Last external number redial	** *	** 0		** 0
Personal number (list No.)	(1-5)			

Functions that need to be programmed by the system administrator:

- Additional lines
- Dedicated intercom link
- Do not disturb*
- Free on 2nd access
- Individual external line
- Manual message waiting
- Name and number log
- Automatic callback*
- Diversion*
- External line
- Immediate speech connection*
- Malicious call tracing
- Multiple representation
- Search profile lists and pre-assigning of function keys for personal number

**Function can be programmed by you.*

When the function is programmed *by you*, you *will not* get a toggle function. Instead you will have one key for activation and another key for deactivation. The key lamp will *not* indicate that the function is activated.

When the function is programmed *by the System Administrator* you will get a toggle function and the key lamp *will* indicate that the function is activated.

Programming of ringing signals

You have 6 programmable ringing signals on your telephone. The different signals can be programmed on access lines, additional lines and multiple represented lines.



Program

Press



Access 1

Press the corresponding line key

A digit (0–6) is shown in the display.

(0 – 6)

Select the ringing signal you want to use according to the list below

- 0 = Silent.
- 1 = Periodic ringing signal.
- 2 = Delayed periodic ringing signal.
- 3 = One muted ringing signal.
- 4 = One muted delayed ringing signal.
- 5 = Immediate speech connection with single tone burst controlled by function key.
- 6 = Immediate speech connection with single tone burst.

Note: Options 5 and 6 are not available for multiple represented lines.



Access 1

Press



Program

Press to finish programming

C



Press to clear the display during programming

To verify a ringing signal



Program

Press



Access 1

Press the corresponding line key

A digit (0–6) is shown in the display.



Program

Press to finish programming

Programming of ringing signal tone character

There are 10 different programmable ringing signal tone characters on your telephone, each corresponding to a digit between 0 and 9.

Note: *If you use melodies to signal incoming calls, this will replace the tone character. See section “Melody ringing” on page 82.*



Program

Press

The current tone character is displayed.

(0 – 9)

Press the corresponding digit

The telephone rings with the chosen character.



Program

Press to finish programming

Handset and loudspeaker volume

Use the volume keys to change the volume of the handset or loudspeaker during a call. Adjust handset listening volume in handset mode. Adjust loudspeaker volume in monitor mode.



Press to change the volume

Ringing signal volume

Use the volume keys to adjust the ringing signal volume when the telephone is idle or ringing. Adjusted volume is stored.



Press to change the volume

Mute ringing signal

You can suppress the ringing signal for an incoming call.

Note: *This function is only available in newer software versions of your telephone. If the Mute key lamp is turned on when you press the key in idle state, your telephone supports this function.*



Press to suppress the ringing signal

The ringing signal is switched off for the current call.

Silent ringing

If you do not want to be disturbed by the ringing signal but still want to be able to answer an incoming call, you can switch off the ringing signal. Incoming calls are only indicated by a flashing access line lamp and display information.

Note: *This function is only available in newer software versions of your telephone. If the Mute key lamp is turned on when you press the key in idle state, your telephone supports this function.*



Press to switch off the ringing signal

The Mute key lamp is switched on to indicate silent ringing. The ringing signal will automatically be switched on the next time you lift the handset or press any key.

Melody ringing

If you want personal melodies when your telephone rings, you can program one melody to signal an internal call, a second melody for an external call and a third melody to signal a callback call.

Note: *This function is only available in newer software versions of your telephone. If you can enter "Melody mode", your telephone supports this function.*

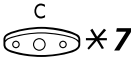

Press and hold simultaneously to enter melody mode



If there is a stored and activated melody for internal calls (Access 1 key), external calls (Access 2 key) or callback calls (Inquiry key), the corresponding key lamp is switched on.

In melody mode you can:

- Program new melodies
- Edit or delete stored melodies
- Activate or deactivate stored melodies



Press to exit melody mode

Note: *If you do not press any key within 30 seconds, melody mode is automatically cancelled.*

Program a new melody, edit or delete a current melody



Program

Press

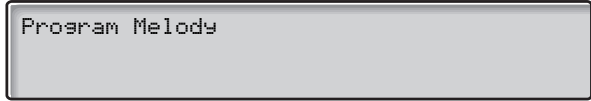

Press the key for the requested type of call:

If there is a current melody, the melody is played and the last 19 notes or signs are displayed.



Access 1

Press for internal calls

or



Access 2

Press for external calls

or



Inquiry

Press for callback calls

To edit the current melody:

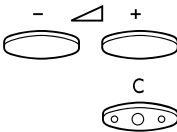

Move the cursor to the right of the position to be edited

Keep pressed to go to the beginning or to the end.

Press to erase the note to the left of the cursor

Keep pressed to erase all the notes.

To enter a new melody or new notes, see section “[To enter notes](#)” on page 85.

To store the current melody:



Press the flashing line key (Access 1 or Access 2 or Inquiry)



Program

Press

The current melody is stored.

Note: *The melody is not activated, see section “[Activate or deactivate a stored melody](#)” on page 84.*



To delete the current melody:

Press and hold until no notes are displayed



Press the flashing line key (Access 1 or Access 2 or Inquiry)



Program

Press

Activate or deactivate a stored melody

A stored melody has to be activated in melody mode to be heard when you get an incoming call.

To activate (in melody mode):



Press the key for the requested type of call (Access 1 or Access 2 or Inquiry)

The corresponding key lamp is switched on:

Access 1 key = Internal calls

Access 2 key = External calls

Inquiry key = Callback calls

Note: *If you want to return to an ordinary ringing signal but keep the melody stored, just press the key for the requested type of call again. When key lamp is off the stored melody is deactivated.*

#

Press to exit melody mode

1c 2d 3e
 4f 5g 6a
 7b 8+c 9+d

To enter notes

In melody mode, the keypad is used to enter notes, pauses, etc. A maximum of 40 notes can be programmed for incoming calls, and 20 notes for recalls.

This is how the keys are used:

Press to insert notes (1–9)

Note: A short press gives a short note, a long press gives a long tone (displayed by a capital letter), +c and +d means the higher octave.

✳

Press to insert a short pause (p)

Hold to get a long pause (P). Repeat to get a longer pause (pp...p).

0

Press to get a higher octave for the inserted note

A + is shown in front of the note to indicate the higher octave.

Example: 30 to get +e

#

Press to increase or decrease the pitch for the inserted note

Press once for sharp pitch, twice for flat pitch and three times to get the normal pitch.

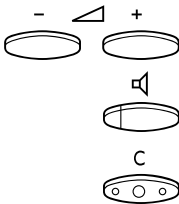

Press to move the cursor to the left or to the right

Keep pressed to go to the beginning or to the end.

Press to listen to the entered notes

Press to erase the note to the left of the cursor

Keep pressed to erase all the notes.

Melody example:

James Bond theme programmed for Internal calls:

C d d D D pp C C C C #d #d #D #D pp D D D ##A G pppp G F G

Enter the notes

Grey digit = Long press.

1 2 2 2 2 ✳ ✳ 1 1 1
 1 2 # 2 # 2 # 2 #
 ✳ ✳ 2 2 2 6 # # 5
 ✳ ✳ ✳ ✳ 5 4 5

Note: The # key (to get a sharp or flat tone) is pressed after the note, but is displayed before the note.

When the first 19 positions are entered, the display shows (only last entered 19 positions can be shown):

```
Program Intern  
CddDDFFCCCC#d#d#D#D<
```

When all the notes are entered, the display shows (only last entered 19 positions are shown):

```
Program Intern  
#D#DFFDDDbAGFFFFGFG<
```











Note: The flat A (##A) is shown as bA, i.e. b is used to show both the note b and the flat sign.

Audible Signals

The following different tones and signals are sent from the exchange to your telephone.

Tone characteristics

The tones shown in this section are the most used tones worldwide. Many markets use a differing tone for one or more situations..

Dial tone	
Special dial tone	
Ringing tone or Queue tone	 every 4th second
Busy tone	
Congestion tone	
Number unobtainable tone	
Call waiting tone	
Intrusion tone	
Conference tone	 every 15th second (to all parties)
Verification tone	
Warning tone, expensive route	

Ringling signals

Three different ringing signals inform you about the type of the incoming call. The signals shown in this section are the most used signals worldwide. Many markets use signals that are adapted for the local standards. If you get a signal that is not described or you cannot identify, ask your system administrator.

Internal ringing signal



External ringing signal



Recall signal
(automatic callback reminder)



Visible Signals

Lamp indications



Extinguished lamp

The function is not active.



Steady light

The function is active or supervised
line is busy.



Slowly flashing lamp

The line (or function) is put on hold.



Rapidly flashing lamp

An incoming call.



Light with short breaks

Ongoing call.

Display Information

The display gives you feedback information such as time and date, traffic state and connected telephone numbers. The following displays show examples of the different states your telephone is in.

When an information end with three dots (...), this means that the system is working or waiting for your action. When an information ends with a exclamation mark (!), this means that no further action is possible.

Idle telephone

When your phone is idle, the upper line shows general information. The middle line shows your extension number. The lower line presents lead texts for the soft keys.

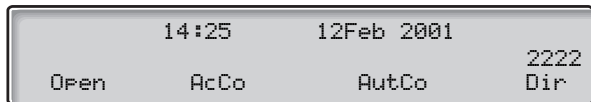

Outgoing call

When you make an outgoing call on your telephone, the middle line shows both the traffic state and dialed number.

	14:25	12Feb 2001	
Calling...			3333
CBack			Time

If the called party's telephone is diverted, the middle line shows the diversion information. > is the diversion symbol.

	14:25	12Feb 2001	
33333 >Direct			5555
CBack			Time

The dialed number (3333) is directly diverted to number 5555.

Incoming call

When you receive an incoming call the middle line flashes the calling party's extension number.

	14:25	12Feb 2001	
33333			

If a diverting extension is calling, the middle line shows the diversion information. The calling party's number is flashing. > is the diversion symbol.

	14:25	12Feb 2001	
44444 >Direct			2222

Number 2222 has dialed number 44444 and the call is directly diverted to you.

Soft keys

The soft keys are used to access different functions. Depending on which traffic state and category of extension, the available functions change.

The following abbreviations are used for the soft keys:

AcCo	Account code
AutCo	Authorization code
Call	Call the number displayed
CBack	Callback
Clr	Reset time measurement
Conf	Conference (only shown when there is a party put on hold)
Cost	Display charging information
CU*	Group call pick-up
CWait	Call waiting
Date	Show date
Del	Delete
DND	Do not disturb
Down	Scroll down
Exit	Exit the displayed menu
Find	Search
Intr	Intrusion
Lock	Lock the telephone
Mal	Malicious call tracing
Next	Show next logged number
Open	Unlock the telephone
Page	Paging
Pick	Call pick-up
RDial	Last number redial
Space	Enter a space when writing names
Start/Stop	Start/Stop time measurement
Time	Display time measurement
Tones	Dialling during a connected call (Push button tones, DTMF)
Up	Scroll up

Choice of language (optional)

One of the following languages can be chosen to be used for the display information on your telephone.

Digit 0–9 = the language code:

0 English 1 French 2 German 3 Spanish 4 Italian
 5 _____ 6 _____ 7 _____ 8 _____ 9 _____

Note: By default 5-9 are programmed for English. To be changed locally to other languages.

To choose a language

08

Press

(0–9)

Enter the language code



Press

Option Unit/Vocabulary

Option unit

The Option unit DBY 410 02 is an optional accessory, to be installed under your telephone set. The following devices can be installed via the Option unit:

- Tape recorder
- Extra bell or busy signal outside your door
- Headset or conference unit

Note: *Regarding the headset functions see section "Other useful facilities".*

- Second handset

Note: *For people with impaired hearing the Option unit offers the possibility to amplify the receiving volume in the handset and headset.*

Vocabulary

Additional lines	One or more additional extension numbers can be assigned to your telephone, these are programmed on free function keys.
Idle message	A message shown in the display when the telephone is idle. This message is programmed by your system administrator.
Multiple represented line	Your extension number can be represented on a function key on other extensions (two or more).
Triple access line	A collective name for the Access 1, Access 2 and Inquiry lines. Access 1 and Access 2 forms your extension number and are available both for incoming and outgoing calls. Inquiry can only be used for outgoing calls.

Installation

Install stand and adapt telephone

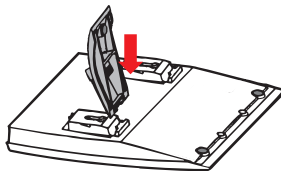

Press to decrease angle

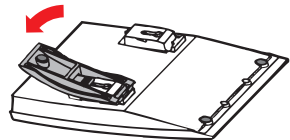

Pull to increase angle

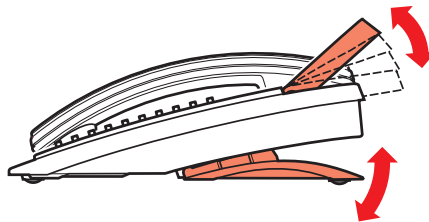
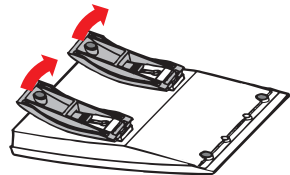
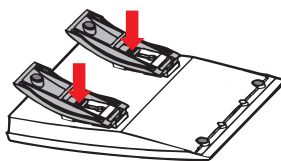

Tiltable display

Adjustable angle

Install cables

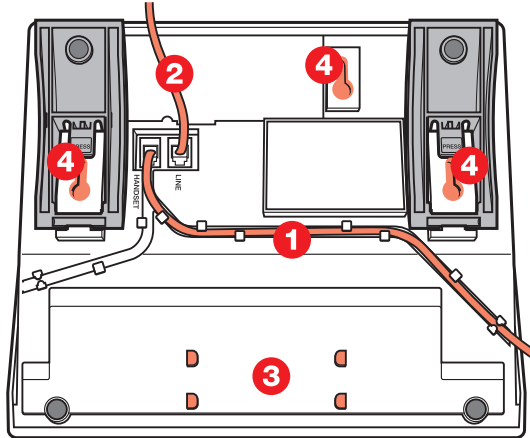

- 1 Cable to handset
- 2 Cable to exchange
- 3 Space for personal directory list(optional)
- 4 Wallmounting screw holes

Wall mounting handset hook

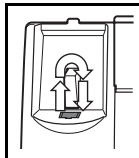

Install keypanel

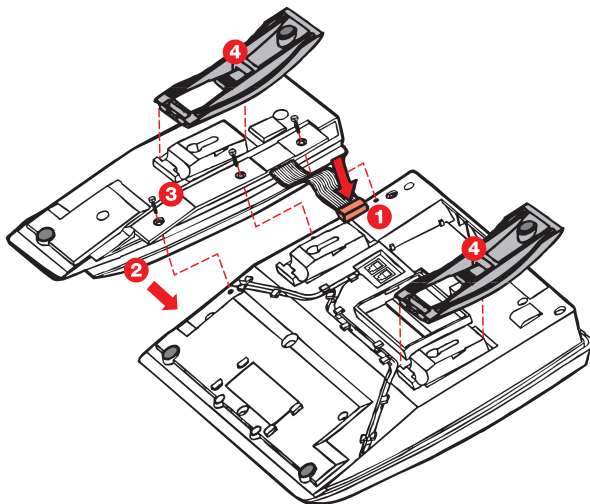

- 1 Remove the small plastic plate, marked DSS, i.e. with a screwdriver and connect the cable
- 2 Attach key-panel unit
- 3 Secure with screws
- 4 Install stand

Index

A

- Abbreviated numbers 45
- Absence information 43
- Account code 54
- Additional directory number 59
- Alarm extension 58
- Alarm paging 69
- Answer calls 9
- Audible signals 87
- Authority 70
- Authorization code, common 73
- Authorization code, individual 74
- Automatic callback 21

B

- Busy extension or external line 21
- Bypass diversion 30

C

- Call forwarding 25
- Call metering 50
- Call pick-up group 52
- Call waiting 23
- Charging information 50
- Choice of language 93
- Common abbreviated numbers 45
- Common bell group 52
- Conference 18

D

- Data communication 59
- Data privacy 70
- Description 4
- Dial by a function key 49
- Dial-by-name 47
- Dialling during a connected call 20
- DISA 63
- Display information 90

- Diversion 25

- Do not disturb, DND 71

- DTMF signals 20

- During calls 15

 - Conference 18

 - Conversation via the handset 16

 - DTMF signals 20

 - Handsfree conversation 16

 - Handsfree to loudspeaking 15

 - Hold 19

 - Inquiry 16

 - Loudspeaking to handsfree 15

 - Microphone on or off 16

 - Send caller's identity code 20

 - Transfer 17

E

- Emergency state 58

- External follow-me 30

F

- Free seating 7

- Functions and required data 77

G

- General cancellation 56

- Group do not disturb 72

- Group facilities 52

- Group hunting 53

- Group listening (loudspeaking) 15

H

- Handset and loudspeaker volume 80

- Handset to handsfree 16

- Handsfree to handset 16

- Headset 60

- Hot line 58

I

Immediate speech connection 55
 Incoming calls 9

- Answer a second call 11
- Handsfree 9
- On Access 9
- On another extension 10
- On any other line key 9

 Individual abbreviated numbers 45
 Information 43
 Inquiry 16
 Installation 95
 Integrated voice mail 40
 Internal follow-me 28
 Internal messages 37
 Intrusion on a busy extension 23

L

Language 93

M

Mailbox 42
 Make calls 12
 Malicious call tracing 60
 Manual message waiting (MMW) 37
 Melody ringing 82
 Message waiting 39
 Messages 37
 Multiple represented directory number 59
 Mute 16
 Mute ringing signal 81

N

Name and number log 64
 Night service 56

O

On hold 19
 Option unit 94
 Other useful facilities 54
 Outgoing calls 12

- External calls 12
- Handsfree 13
- Individual external line 13
- Internal calls 12
- Last external number redial 14

Save external number 14

P

Paging 65

- Alarm paging 69
- Paging receivers with a display 67
- Paging receivers with voice message 68
- Paging receivers without a display and paging via lamp signals 66

 Personal number 31
 Programming and adjustments 76
 Programming of functions 76
 Programming of ringing signal tone character 80
 Programming of ringing signals 79
 Put a call on hold 19

R

Redial number 14
 Refer back 17
 Ringing signal volume 80
 Ringing signals 88

S

Send caller identity code at transfer 20
 Setting form for search profiles 36
 Short numbers 45
 Silent ringing 81

T

Timer 51
 Tone characteristics 87
 Transfer 17

V

Visible signals 89
 Vocabulary 94
 Voice mail 40
 Volume 80

W

When you receive a busy tone 21

- Call waiting 23
- Intrusion 23

Ericsson is shaping the future of Mobile and Broadband Internet communications through its continuous technology leadership. Providing innovative solutions in more than 140 countries, Ericsson is helping to create the most powerful communication companies in the world.

Ericsson Enterprise AB
All rights reserved.
For questions regarding the product,
please contact your Ericsson Enterprise Certified Sales Partner.
Also visit us on <http://www.ericsson.com/enterprise>

© Ericsson Enterprise AB 2002
EN/LZT 103 24 R1A